

THE

# General Radio EXPERIMENTER



VOLUME XII NO. 11

APRIL 1938

ELECTRICAL MEASUREMENTS AND THEIR INDUSTRIAL APPLICATIONS

<b>Also</b>	
<b>IN THIS ISSUE</b>	
THE BEHAVIOR OF TYPE 505 CONDENSERS AT HIGH FREQUENCIES	Page 4

## A-C OPERATION FOR TYPE 613-B BEAT-FREQUENCY OSCILLATOR

● THE TYPE 613-B BEAT-FREQUENCY OSCILLATOR, a low-power, battery-operated instrument, has had a wide use in laboratories. Small in size and simple

in operation, it is a convenient instrument to use for laboratory and field testing. Many users, however, have felt a need for a-c operation of this oscillator, particularly in permanent installations.

To satisfy this demand, we have developed the TYPE 613-P1 Power Supply. Designed specifically for use with the TYPE 613-B, this power

FIGURE 1. The TYPE 613-B Beat-Frequency Oscillator with TYPE 613-P1 Power Supply installed

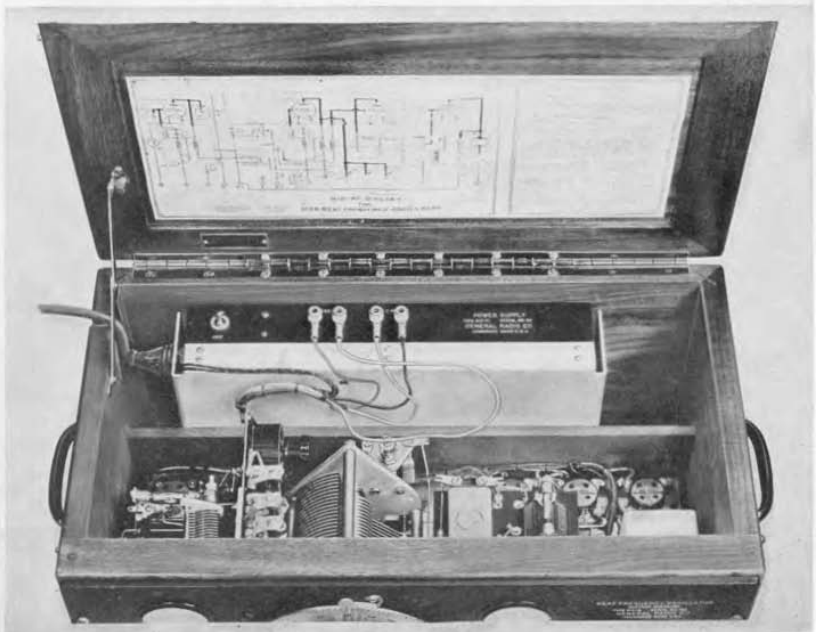

IET LABS, INC in the GenRad tradition  
534 Main Street, Westbury, NY 11590

TEL: (516) 334-5959 • (800) 899-8438 • FAX: (516) 334-5988

www.ietlabs.com

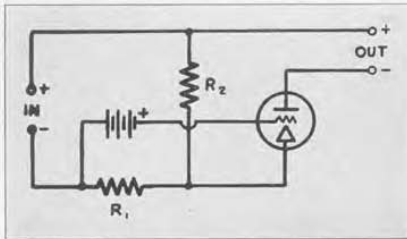

FIGURE 2. Schematic diagram of the voltage regulator

unit fits the battery compartment of the oscillator and need not be permanently installed. The shift from batteries to a-c supply and vice versa can be made in a few seconds, so that the oscillator can be used with a-c supply in the laboratory and with batteries in the field.

Figure 1 is a photograph of the power supply unit itself and Figure 2 shows it installed in the oscillator cabinet. On recent models of the oscillator (Serial No. 402 and above), the ON-OFF switch is arranged to break the a-c line feeding the power supply. On older models,

where the panel switch breaks only the filament circuit, the plate supply can be turned off by using a switch provided on the TYPE 613-P1 Unit, or a new switch can be installed in the oscillator by the user.

The circuit of the power supply unit is shown in Figure 3. In the low-voltage circuit for supplying the filaments, a copper-oxide rectifier with adequate filtering is used. The usual thermionic rectifier is used in the high-voltage circuit.

One important feature is the built-in voltage regulator which keeps the output voltage constant over a wide range of line voltages. This is a vacuum-tube type of regulator and is shown in simple form in Figure 4. When the ratio  $\frac{R_2}{R_1}$  is made equal to the amplification constant of the vacuum tube, constant voltage is obtained at the output terminals for a wide range of input voltages. By means of the bias  $E_b$  the output voltage can be adjusted to the desired value. In the TYPE 613-P1 Power Supply, the bias  $E_b$  is obtained from the constant voltage drop

FIGURE 3. Interior view of the TYPE 613-P1 Power Supply

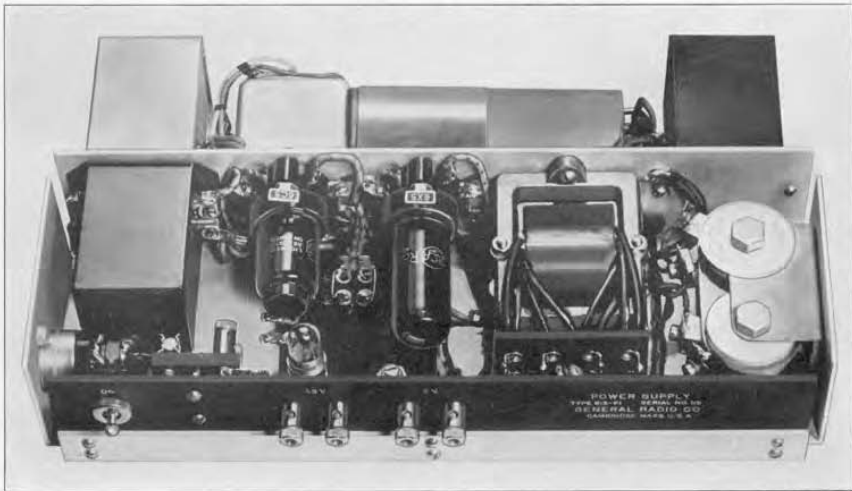

across the neon lamp, *V-3*, and is adjustable by means of the slider on *R-7*.

Excellent voltage regulation is provided by using this system. With the normal load of the TYPE 613-B Beat-Frequency Oscillator, the output voltage varies between 134 and 137 volts for a line voltage range of 100 to 130 volts.

The line-frequency hum level has been kept low by using adequate filtering and by providing an electrostatic shield between the primary and secondary windings of the power transformer. The hum

amplitude appearing in the oscillator output is less than 2 millivolts for all line voltage and frequency combinations except 120-130 volts, 42 cycles, where it rises to 3 millivolts. This is equivalent to about 0.01% of open circuit output voltage.

This instrument will operate on all line frequencies between 40 and 60 cycles. Total power input is approximately 15 watts.

**SPECIFICATIONS**

**Output:** 2 volts, 0.3 a and 135 volts, 8.5 ma.  
**Input:** 15 watts at 100 to 130 volts, 40 to 60 cycles.

**Tubes:** One 6X5, one 6C5, one T-4½ neon lamp. All tubes are supplied.

**Mounting:** Sheet aluminum frame and base to fit battery compartment of TYPE 613-B Beat-Frequency Oscillator.

**Terminals:** Output voltages are available at terminals for connecting battery leads of TYPE 613-B Beat-Frequency Oscillator.

**Other Accessories Supplied:** Line cord-and-plug assembly; spare fuses; spare neon lamp.

**Dimensions:** 13½ x 8¾ x 2½ inches, over-all.  
**Net Weight:** 12½ pounds.

Type	Code Word	Price
613-P1	POWPACKANT	\$70.00

FIGURE 4. Complete circuit diagram of the TYPE 613-P1 Power Supply

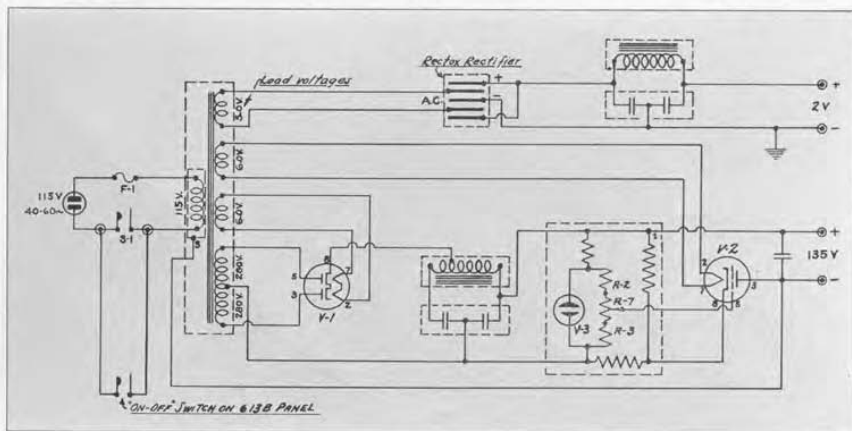



## THE BEHAVIOR OF TYPE 505 CONDENSERS AT HIGH FREQUENCIES



● MUCH ATTENTION HAS BEEN DIRECTED to the determination of the frequency characteristics of fixed and variable resistors and of variable capacitors because these elements are most generally used as impedance standards. Correspondingly precise information on the frequency characteristics of fixed capacitors has not been readily available.

A brief description of the behavior of TYPE 505 Condensers at frequencies from 50 cycles to 10 Mc seems warranted in view of the uses which many experimenters are now making of these capacitors in high-frequency circuits.

### ANALYSIS

In theory, a perfect fixed capacitor would have a pure unvarying capacitance, with no residual inductance and resistance. In practice, of course, such a capacitor cannot be physically realized. An actual capacitor has a true capacitance which varies with frequency in exactly the same manner as does the dielectric constant of the solid dielectric between the plates; it has a residual inductance caused by the magnetic flux set up by the currents in the leads and

plates; it has energy losses in the solid dielectric material and, finally, it has energy losses in the metallic structure and in the leads.

As in the case of the variable capacitor,\* a fixed mica capacitor may be represented by the equivalent circuit shown in Figure 1.

In this figure,  $L$  represents the residual inductance of the capacitor,  $R$  the effective series resistance corresponding to losses in the metallic structure,  $G$  the effective parallel conductance corresponding to losses in the solid dielectric material, and  $C$  the true capacitance.

The true capacitance,  $C$ , as predicted by the Debye† polar molecule theory, should be essentially constant for frequencies up to a transition region in which a decrease in the dielectric constant and a peak in power factor take place. This transition region for mica apparently is absent or occurs at very high frequencies as no such shift in dielectric constant is observed in the region between 50 cycles and 10 Mc. A slight in-

\*R. F. Field and D. B. Sinclair, "A Method for Determining the Residual Inductance and Resistance of a Variable Air Condenser at Radio Frequencies," *Proceedings of the I.R.E.*, February, 1935.

†For an authoritative review of contemporary knowledge of dielectric behavior, see E. J. Murphy and S. O. Morgan, "The Dielectric Properties of Insulating Materials," *Bell System Technical Journal*, October, 1937.

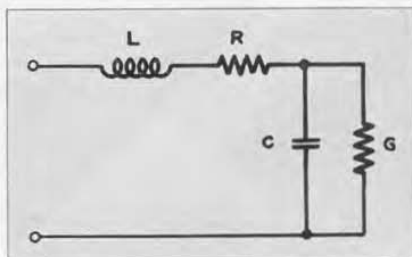

FIGURE 1. Equivalent circuit of a fixed mica capacitor

crease in effective capacitance occurs at low audio frequencies, however, because of dielectric absorption.

The residual conductance,  $G$ , varies with frequency in a rather complicated manner. For many good solid dielectric materials it has been found that the energy loss per cycle per squared potential gradient is essentially constant, irrespective of frequency, and that the conductance,  $G$ , therefore increases linearly with frequency\*. While this simple law holds very well for variable capacitors having ceramic or quartz insulation, it breaks down for fixed mica capacitors such as the TYPE 505. At low frequencies, losses caused by absorption currents appear to predominate, and the conductance,  $G$ , has been found experimentally to follow the law

$$G = k\omega^{1-n}$$

\*The power loss is given by  $E^2G$ . If the energy loss per cycle is constant, the total energy loss per second is directly proportional to frequency, and the effective conductance,  $G$ , increases linearly with frequency. This relation may also be derived from the more common statement that the loss factor (power factor  $\times$  dielectric constant) is constant.

$$\text{Loss factor} = \frac{G}{\omega C} \times \epsilon = \frac{G}{\omega C} \times \frac{C}{C_0} = \frac{G}{\omega} \frac{1}{C_0}$$

where  $E$  is the dielectric constant at any frequency and  $C_0$  the capacitance which would exist for  $\epsilon = 1$ .

FIGURE 2. The effective capacitance values for four standard TYPE 505 Condensers. Since the low-frequency rise in capacitance would not be noticeable on a plot to this scale, values below 10 kc are not shown

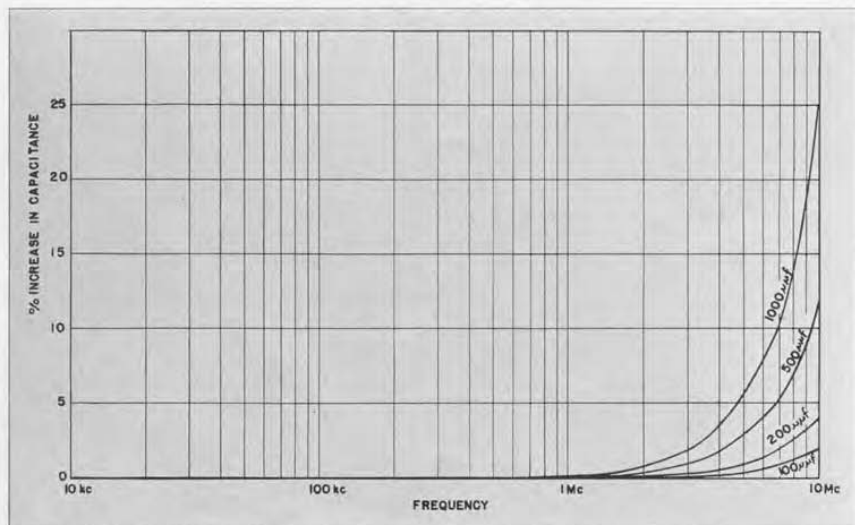

where  $n$  is approximately equal to 0.2.† At higher frequencies the conductance,  $G$ , increases linearly with the frequency.‡

The power factor component contributed by the dielectric loss is given by the expression  $\frac{G}{\omega C}$ . At low frequencies the power factor component therefore varies with frequency as  $\frac{1}{f^n}$  and at high frequencies the power factor component is constant.

The residual inductance,  $L$ , is constant with frequency. It introduces a component of positive reactance in series with the negative reactance of the true capacitance and consequently causes the effective terminal capacitance  $C_e$  to de-

†See, for instance, H. J. MacLeod, "Power Loss in Dielectrics: Variations with Frequency," *Phys. Rev.*, Vol. 21, No. 1, p. 53; January, 1923.

‡At very low frequencies, a further component of loss is introduced by the actual leakage conductance through and over the surface of the solid dielectric. Since the leakage conductance of TYPE 505 Condensers is of the order of 0.0005 µmho per microfarad, this loss is ordinarily negligible.

part from the true capacitance,  $C$ , at high frequencies.

The residual resistance,  $R$ , contributes a negligibly small loss at low frequencies since it is in series with a high capacitive reactance. As the frequency increases, however, the capacitive reactance drops in relation to the residual resistance and the power factor component contributed by metallic losses first becomes comparable with and finally exceeds the component contributed by dielectric losses. The power factor component corresponding to metallic loss is given by the expression  $R\omega C_e$ . This component actually rises more rapidly than the first power of the frequency because of skin effect in the metal parts and because  $C_e$  increases with frequency.

MEASUREMENT

A plot of the effective capacitances of four standard TYPE 505 Condensers as a function of frequency is shown in Figure 2. The capacitances rise slightly at low

<sup>2</sup>The capacitance rise at low frequencies is too small to be visible on the plot of FIGURE 2. The rise is essentially the same for all four capacitors and amounts to about 0.1  $\mu\text{f}$  at 2000 cycles, 0.2  $\mu\text{f}$  at 400 cycles, 0.3  $\mu\text{f}$  at 150 cycles, 0.4  $\mu\text{f}$  at 85 cycles, and 0.5  $\mu\text{f}$  at 50 cycles with the capa-

frequencies,\* remain constant for medium frequencies, and rise sharply at high frequencies. The rise at high frequencies depends upon the residual inductance,  $L$ , which causes the effective terminal capacitance to follow the law

$$C_e = \frac{C}{1 - \omega^2 LC} \quad (1)$$

Equation (1) shows that the fractional rise in capacitance at high frequencies increases with the true capacitance  $C$ . From the experimental curves it can be seen that this law holds true in general. The 1000  $\mu\text{f}$  capacitor shows a rise of 1% at a frequency of 2.2 Mc. The 100  $\mu\text{f}$  capacitor does not rise 1% until a frequency of 7.2 Mc has been reached.

From the increase in effective capacitance at high frequencies the value of the residual inductance may be deduced. Maximum precision in determining the inductance is secured by plotting, in the form of a straight line, data taken at several frequencies.

From Equation (1)

$$\frac{1}{C_e} = \frac{1}{C} - \omega^2 L$$

itance at 100 kc taken as reference. The reason that the capacitance rise is not dependent upon the size of the capacitors appears to be that a large part of the absorption is in the yellow bakelite cases, sealing compound, and residual moisture, and not in the mica.

FIGURE 3. Variation of power factor with frequency for the four sample condensers

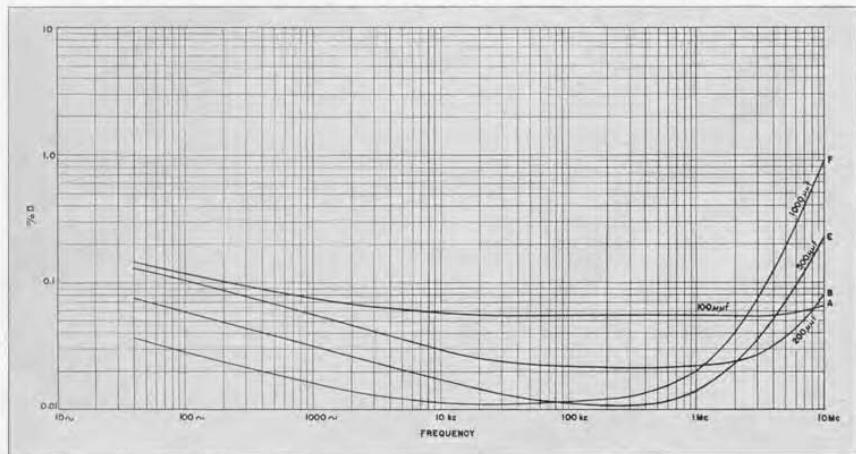
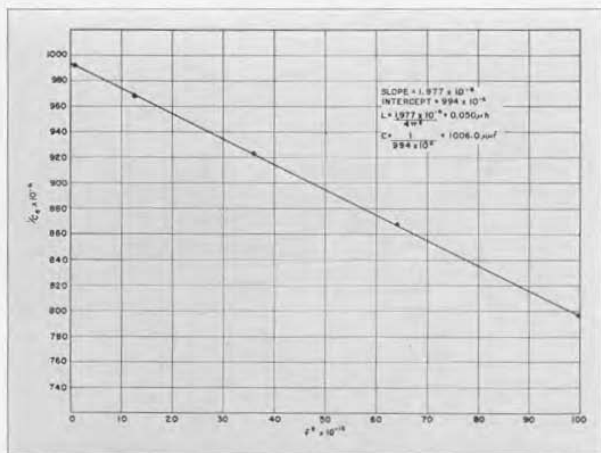



FIGURE 4. The straight-line plot from which the inductance of the 1000  $\mu\mu\text{f}$  capacitor was obtained. The points shown are those determined experimentally



Therefore, if  $\frac{1}{C_e}$  be plotted as a function of  $\omega^2$  over the frequency region for which  $C$  is constant, a straight line is obtained. The intercept of the straight line with the ordinate axis is equal to  $\frac{1}{C}$  and the slope is equal to  $L$ .

Figure 4 illustrates the experimental straight-line plot for the 1000  $\mu\mu\text{f}$  TYPE 505-F Condenser. From the precision with which the experimental points fall on the straight line, it is clear that the implicit assumptions that  $L$  and  $C$  are constant over the frequency range are valid.

The values of  $C$  obtained from the intercepts check the 100 kc capacitance values well within the precision of measurement. The values of residual inductance formed for the four capacitors are all sensibly equal as shown in the following table:

Type	Capacitance	Inductance
505-A	100 $\mu\mu\text{f}$	0.055 $\mu\text{h}$
505-B	200 $\mu\mu\text{f}$	0.053 $\mu\text{h}$
505-E	500 $\mu\mu\text{f}$	0.054 $\mu\text{h}$
505-F	1000 $\mu\mu\text{f}$	0.050 $\mu\text{h}$

This close agreement, despite the difference in rated capacitance, is taken to mean that the inductance is largely localized in the leads to the capacitors.

Curves of the power factors of these capacitors are shown in Figure 3. The general expression for power factor must include a factor which expresses the dielectric loss and a factor which expresses the metallic loss, as follows

$$D = \frac{G}{\omega C_e} + R\omega C_e \quad (2)$$

The first component corresponds to the dielectric loss. At very low frequencies the conductance,  $G$ , varies approximately as  $f^{0.8}$ . The power factor component, therefore, varies as  $1/f^{0.2}$ . At higher frequencies  $G$  varies directly as  $f$  and the power factor component is constant.

The second component corresponds to the metallic loss. At high frequencies, where it becomes appreciable compared with the dielectric loss component, skin effect in the metal parts is essentially complete and the residual resistance,  $R$ , varies approximately as  $f^{\frac{1}{2}}$ . The power factor component therefore varies as  $f^{\frac{3}{2}}$ .

Equation (2) shows that the power factor rise at high frequencies varies directly as the effective capacitance  $C_e$ . The curves of Figure 3 are seen to bear out this general law. The power factor of the 1000  $\mu\mu\text{f}$  condenser begins to rise at a frequency of about 200 kc. The power factor of the 100  $\mu\mu\text{f}$  condenser does not begin to rise appreciably until the frequency reaches 5 Mc.

The residual series resistance,  $R$ , causing the high-frequency power factor rise, is roughly the same for all four capacitors. It is therefore believed to reside largely in the leads from the capacitor binding posts to the capacitor plates. The magnitude of the resistance causing the rise is small, about 0.003  $\Omega$  at 1 Mc and 0.008  $\Omega$  at 10 Mc. It is difficult to reduce this resistance because, when skin effect is complete, the resistance is proportional to the superficial area of the leads and not the cross-sectional area. It has been computed that, in order to reduce the resistance by a factor of 10, it would be necessary to use leads consisting of  $\frac{1}{2}$ -inch copper rod or tubing.

The power factors of all four capacitors are seen to follow the general trend

predicted by the foregoing analysis but they are translated in a vertical direction. This effect is partly caused by losses in the yellow bakelite case, in the sealing compound, and in residual moisture. In each capacitor 2 to 3  $\mu\mu\text{f}$  of the terminal capacitance occurs between the terminals themselves, with the case material and sealing compound as dielectric. The power factors of these materials are far inferior to the power factor of the mica. As the rated capacitance is increased, the proportion of poor dielectric to good dielectric decreases and, consequently, the over-all power factor is improved and the curves shift downwards.

The experimental data at frequencies from 50 cycles to 50 kilocycles were taken with the General Radio TYPE 716-A Capacitance Bridge, using both the Schering and parallel resistance connections; data were taken at frequencies from 160 kc to 4 Mc with the General Radio TYPE 516-C Radio-Frequency Bridge. At frequencies from 5 Mc to 10 Mc a parallel-resonance circuit was used. In all cases measurements were made with a parallel substitution method.

— D. B. SINCLAIR

***T***HE General Radio EXPERIMENTER is mailed without charge each month to engineers, scientists, technicians, and others interested in communication-frequency measurement and control problems. When sending requests for subscriptions and address-change notices, please supply the following information: name, company name, company address, type of business company is engaged in, and title or position of individual.

## GENERAL RADIO COMPANY

30 STATE STREET - CAMBRIDGE A, MASSACHUSETTS

BRANCH ENGINEERING OFFICES

90 WEST STREET, NEW YORK CITY

1000 NORTH SEWARD STREET, LOS ANGELES, CALIFORNIA



IET LABS, INC in the GenRad tradition

534 Main Street, Westbury, NY 11590

TEL: (516) 334-5959 • (800) 899-8438 • FAX: (516) 334-5988

www.ietlabs.com