

the GENERAL RADIO Experimenter



©1956 • GENERAL RADIO Company, Cambridge, Mass., U. S. A.

Since 1915 — Manufacturers of Electronic Apparatus for Science and Industry

VOLUME 31 No. 1

JUNE, 1956

A HIGH-PRECISION CALIBRATOR FOR FREQUENCY AND TIME

The TYPE 1213-C Unit Time/Frequency Calibrator is in no sense a simple redesign of its predecessor, the TYPE 1213-AB Unit Crystal Oscillator.¹ It is an all-new design that reflects both the field experience gained from the earlier instrument and the advances in electronic circuit techniques over the past five years. The new calibrator comprises, in a small unit-type case, all the circuits necessary for the frequency calibration of oscillators, receivers, and other wide-range devices up to frequencies somewhat above 1000 megacycles; and for the sweep-time calibration of oscilloscopes at intervals from 0.1 μ sec to 100 μ sec.

A comparison of the old and new

instruments show four important new features of the Time/Frequency Calibrator:

- (1) 10-Mc harmonic series.
- (2) A crystal mixer good from low frequencies to frequencies above 1000 Mc.
- (3) An amplifier for audible beats, which makes possible direct calibration of oscillators up to 1000 Mc.
- (4) A video amplifier for the multi-vibrator output to permit oscilloscope time-axis calibration and to make the output standard-frequency wave-forms available for driving external pulse equipment.

Additional features are ease and re-settability of calibration, frequency deviation with no disturbance of calibration, and improved frequency stability and reliability.

¹R. B. Richmond, "Unit Crystal Oscillator," *General Radio Experimenter*, Feb., 1952.

"Improved Unit Crystal Oscillator," *General Radio Experimenter*, Sept., 1955.

Figure 1. Panel view of the Type 1213-C Unit Time/Frequency Calibrator with Unit Power Supply.



IET LABS, INC in the GenRad tradition

534 Main Street, Westbury, NY 11590

www.ietlabs.com

TEL: (516) 334-5959 • (800) 899-8438 • FAX: (516) 334-5988

Of particular importance is reliability, which is becoming of more and more concern in these days of increasing electronic complexity. The TYPE 1213-C Unit Time/Frequency Calibrator, containing only seven vacuum tubes, is not in the class with instruments requiring a major reliability analysis; yet it reflects thinking on the subject which will be applied to instruments more than on order of magnitude more complex. The multivibrators, used as frequency dividers in this instrument, represent a new concept of multivibrator reliability in measuring instruments. They are classical Abraham-Bloch² multivibrators, designed by analytical procedures to produce maximum immunity to tube-characteristic deterioration. These multivibrators are discussed in some detail in the circuits section of this article.

BLOCK DIAGRAM

The basic circuits used in the Unit Time/Frequency Calibrator are shown in Fig. 2. They consist of:

- (1) A 5-Mc crystal oscillator electron-coupled to a 2:1 multiplier.
- (2) A 10-Mc buffer stage.
- (3) A group of three multivibrators

controlled by a panel switch and dividing the 10-Mc crystal controlled frequency by factors of 10, 100, and 1000.

(4) A harmonic generator which will produce a continuous harmonic spectrum of the 10-Mc, 1-Mc, 100-ke and 10-ke signals from the multivibrator.

(5) A crystal mixer either to couple the harmonics out of the instrument on a coaxial lead, or to produce and to detect a beat against a signal fed into the mixer.

(6) An amplifier stage, switched either to amplify the audio beat signal from the mixer or to produce a video signal for oscilloscope calibration.

CIRCUITS

Oscillator

A hermetically sealed, AT-cut, 5-Mc quartz crystal is used as a frequency control element for the oscillator. The electron-coupled Gouriet-Clapp³ oscillator circuit uses the first control-grid-screen-grid space of a pentagrid converter tube to provide the oscillating loop gain. Output is taken from the plate circuit of the pentagrid tube, which is tuned to resonance at 10 Mc.

Buffer

The 10-Mc signal at the plate of the

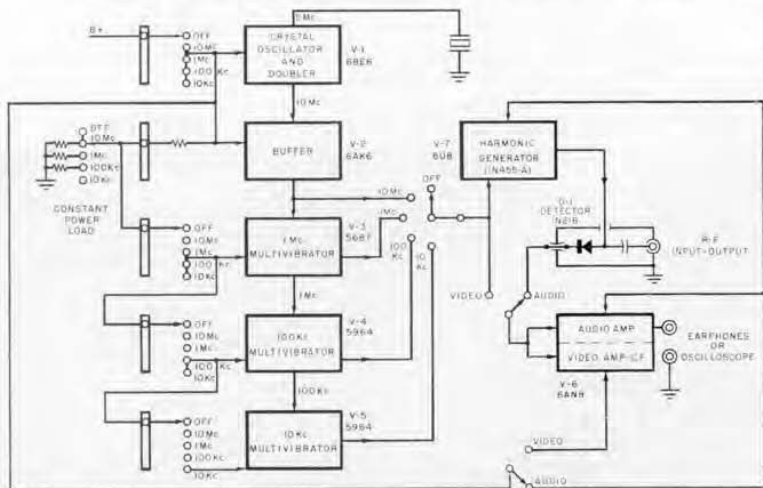

²Abraham, H. and Bloch, E., "Notice sur les Lampes-Valves a 3-Electrode et leurs Applications," Publication 27 of the French War Ministry, April, 1918.
³Clapp, J. K., "Frequency-Stable L-C Oscillators," Proc. IRE, 42, 8; August, 1954; page 1295.

Figure 2. Block diagram of the calibrator, showing the basic circuits.



oscillator drives a pentode buffer. The 45-volt buffer output at 10 Mc drives the 1-Mc multivibrator and either the harmonic generator or video amplifier, depending upon the position of the audio/video selector switch. The buffer output also feeds a germanium diode rectifier circuit, which produces a d-c voltage for audio amplitude control.

Multivibrators

Three multivibrators of a design intended to produce maximum reliability are used to divide the 10-Mc buffer frequency to produce the standard 1-Mc, 100-ke and 10-ke frequencies. These carefully designed and constructed multivibrators will insure long and trouble-free operation without regulated voltage supplies and with no readjustments of the circuit when tubes are replaced. A typical circuit is shown in Figure 3. It will be recognized as the simplest form of the astable multivibrator. The design has been carefully studied and optimized for reliability by:

(1) Exact adjustment of all controllable circuit parameters, and trigger amplitude to the correct values to permit maximum tube degradation before failure.

(2) Choice of the operating point for the tubes so that the multivibrator performance as determined by the conducting-tube plate voltage is least affected by the aging of the tube.

Figure 4 shows the timing action of

the multivibrator of Figure 3. Assume that from t_0 to t_1 , V_1 is off; and, at t_1 , V_1 switches on and quickly by the loop regeneration is brought to and beyond zero bias. (For the purposes of this discussion, neglect the positive grid transient.) Now after time t_1 , the plate voltage (E_{b10}) of $V-1$ is at a low value depending on the zero-bias plate current and R_{L1} . C_{c2} must discharge through R_{g2} toward E_{bb} , and it will continue to discharge until the cutoff of $V-2$ is reached, whereupon the two tubes will again switch, with $V-2$ going on and $V-1$ off. We can now write down the equation for the timing action determined by the discharge of the grid coupling RC circuit and the amplitude of the plate swing.

$$T = R_{g2} C_{c2} \log_e \frac{E_{bb} + E_{p10}}{E_{bb} + E_{c02}} \quad (1)$$

and since $E_{c02} = E_{bb} / \mu_{c02}$,

$$T = R_{g2} C_{c2} \log_e \frac{1 + \frac{E_{p10}}{E_{bb}}}{1 + \frac{1}{\mu_{c02}}} \quad (2)$$

Since $E_{p10} = i_{p10} R_{L1}$ equation (2) shows all of the important circuit variables. The quantity μ_{c02} is a function of tube geometry and does not change appreciably with tube life, so attention need only be given to the RC product $R_{g2} C_{c2}$ and i_{p10} .

How are these quantities used to optimize the design of a triggered multivibrator? Consider Figure 5 where the

Figure 3 (below). Schematic circuit diagram of typical 2-tube multivibrator.

Figure 4 (right). Timing diagram for multivibrator of Figure 3 showing typical plate-voltage waveforms.

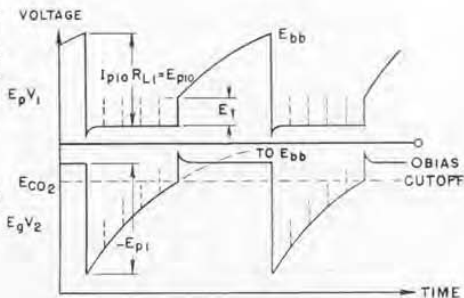
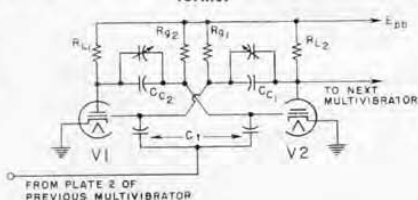



timing waveform has been linearized to illustrate the triggering principles, so that the time equation is modified as shown in equation (3)

$$T = KRCE_{pi} \quad (3)$$

A study of Figure 5 and Equation (3) makes it obvious that, for maximum locking range on the n th trigger with arbitrary variations of e_p and the RC slope, the trigger amplitude (E_t) must be set at a value determined by the plate swing as stated in Equation (4)

$$E_t = \frac{E_{p10} - E_{o02}}{n + \frac{1}{2}} \quad (4)$$

This is the optimum trigger-voltage amplitude, and the intercept of the grid discharge voltage waveform with the cutoff line in the absence of triggering pulses must be at a time of $n + \frac{1}{2}$ units, where the time unit is that established by the interval between trigger pulses. The proof that Equation (4) does provide the optimum trigger amplitude follows. Consider the locking conditions for values of E_t greater than and less than the optimum value given in equation (4); (1) When the plate swing E_{p10} varies through values greater than and less than the design value with the slope constant, and (2) When the range of slope values is greater and lesser than the original

slope with E_{p10} held constant. It can be seen that values of trigger voltage greater than and less than that determined by Equation (4) will decrease the locking range of the multivibrator, by having it jump to a lock on the 4th or 6th triggering pulse when E_t is greater, or by having it go out of lock completely when E_t is less.

There is an inescapable conclusion that follows from this simple analysis. One is allowed a total deviation of $\pm \frac{1}{2} E_t$ in the value of the grid discharge voltage level at the time of the n th trigger pulse at which the multivibrator should switch. Therefore, in a symmetrical multivibrator dividing by 10 (n equals 5 on each half-cycle of the multivibrator), a change of approximately $\pm 9\%$ in the combination of E_{p0} and RC will cause a failure in the count. Since emission varies with time, one must remove any controllable fixed errors in order to transfer all allowable variation to the tube, which is bound to change with time. This is done by using adjustable components to remove any effect due to component tolerances on the $R-C$ time constants. An important fact that must be recognized is that the plate current of vacuum tubes seldom rises with age. Initial adjustment can thus be made to take advantage of this fact by setting the $R-C$ time constant on the long side so that the tolerance for changes in plate current approximates $+3$ and -15% .

The facts presented above apply to all stable multivibrators no matter how operated. When the multivibrator frequency is below 100 kc, techniques of "hard-bottoming"⁴ can be applied.

The plate resistors for all multivi-

Figure 5. Linearized timing-waveform diagram for the multivibrator of Figure 3.

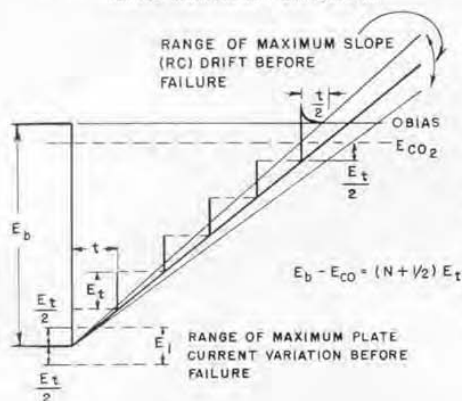

⁴Harris, C. C., "The 'Hard-Bottoming' Technique in Nuclear Instrumentation Circuit Design," *IRE Transactions on Nuclear Science*, NS-3, 2; March 1956; page 5.





brators of this design are always set at their maximum allowable value. This value is determined by the time necessary to recharge the coupling capacitor after the switching interval in which the tube is turned off. The plate voltage should recover to value near the supply voltage⁵. The largest possible value of plate-load resistance gives the best approach to the "hard-bottomed" characteristic and offers the additional features of minimum plate dissipation for the tube and minimum plate current, which tend to increase tube life.

Experimentally, multivibrators designed on this basis have proved to be extremely reliable. For example, a string of eight such units dividing frequency from 10 Mc have operated a clock with 10-second pulses for over nine months, 6,500 hours, without a failure caused by a vacuum tube.

The three frequency-dividing multivibrators are added serially to the circuit system by the frequency selector switch on the front panel. This switch turns the plate power on and connects the appropriate multivibrator to either the harmonic generator or the video amplifier. Throughout this switching operation, the power dissipated in the unit is held constant by the insertion of dummy load resistors so that the box temperature will remain as nearly constant as possible.

Amplifiers

The audio-video switch selects the two input-output types of operation. When the unit is to be used for time calibration with the switch in the video position, the output of the 10-Mc buffer or of one of the multivibrators is connected to the grid of

the video amplifier. This stage is a pentode amplifier-limiter feeding a cathode follower. The cathode follower is connected by the switch to a terminal pair on the panel and provides a low-impedance source to drive external circuits. When the audio-video switch is thrown to the audio position, the following changes in circuitry are effected: (1) the amplifier stage is converted to a two-stage audio amplifier with 5-ke bandwidth and a voltage gain of about 70 db connected to the silicon-crystal mixer output (Figure 6); and (2) the 10-Mc buffer or one of the multivibrator outputs is connected to the harmonic generator.

Harmonic Generator

The harmonic generator consists of two stages, the first a pentode limiter-driver, and the second a triode used to drive the germanium-crystal diode harmonic generator. The plate of the pentode section is tuned when the frequency selector switch is in the 1 and 10 Mc positions, and it acts as an untuned amplifier in the 100-ke and 10-ke positions. The pentode stage between the multivibrators and harmonic generator removes most of the trigger pulse that occurs on the multivibrator waveforms and which would otherwise make the harmonic spectrum non-uniform. The triode harmonic generating stage and its connection to the mixer are shown in Figure 6. The driving waveform switches the plate current off and on, and the impedance discontinuity offered by the crystal diode when the plate current switches on generates a very sharp negative-going spike of voltage. The criterion for the crystal diode used in this application is that the front resistance should be as low as possible. Hence, one of the new "VLI" diodes, the 1N455, is used in

⁵Shenk, E. R., "The Multivibrator — Applied Theory and Design," *Electronics*, January 1944; page 136.





this application. It is the sharp voltage spike that produces the uniform spectrum of harmonics fed to the mixer.

Mixer

The mixer used in the Unit Time/Frequency Calibrator is a new design combining good high-frequency performance with compactness, accessibility for crystal replacement, and protection for the crystal diode. The coaxial panel fitting serves the double purpose of either coupling the r-f spectrum to external systems as an output connector, or as an input fitting to accept an externally produced r-f signal to be mixed with the standardized r-f spectrum. A built-in coaxial coupling capacitor protects the 1N21B crystal mixer against surges from connecting external circuits. The mixer current is produced by the harmonic-generator waveform, so that with small injected signals, the injected signal does not materially affect the efficiency of the mixer.

The gain of the audio amplifier is controlled in a non-linear fashion by adjustment of grid bias on the second audio stage. Enough bias is applied to cut the tube off for small signals so that undesired beats of harmonics of the

standard frequency signal between harmonics of the unknown signal can be rejected.

Power Supply

The Unit Time/Frequency Calibrator is designed to work with either the General Radio TYPE 1203-A or 1201-A Power Supplies. Power requirements are 300 volts, 60 milliamperes, 6.3 volts, 3.15 amperes. The TYPE 1201-A Regulated Supply is recommended for minimum hum and maximum frequency stability.

Construction

All of the circuits except the harmonic-generator stage are located on a single etched board. This board has an etched ground plane under the crystal oscillator, buffer and audio-video amplifier circuits. Distributed-capacitance loading on the multivibrator is reduced by omitting the ground plane under these circuits. Careful consideration of component layout and shielding on this board insures a good environment for the crystal oscillator free of thermal transients and electrical interference. The multivibrator time constants are controlled by precision components with mica capacitors and glass trimmer capacitors. These components insure good multivibrator performance and long life.

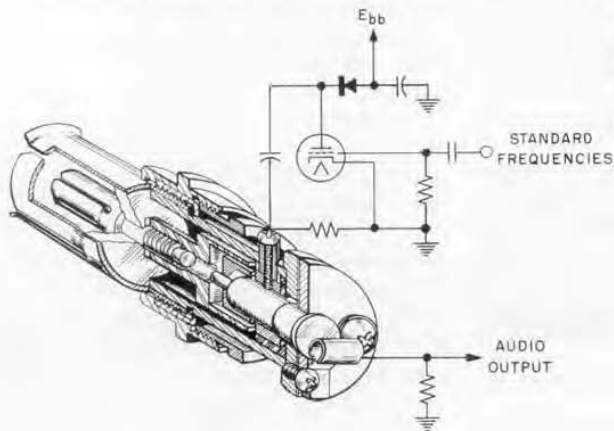

Figure 6. Cutaway view of the crystal mixer, with schematic of triode harmonic-generating stage.





APPLICATIONS

The TYPE 1213-C Unit Time/Frequency Calibrator used with the required power supply and headphones provides all the necessary apparatus for the calibration of radio-frequency oscillators and receivers to frequencies beyond 1000 Mc, and it also provides square-wave markers for oscilloscope sweep-time calibration. A simple plug-in device, the TYPE 1213-P1 Differentiator (supplied as an accessory) converts these square waves to brief pulses. The output pulse has been made powerful enough to trigger most pulse generators and oscilloscope sweeps, thus providing a stable driving source for timing pulse systems for various applications.

The calibration of oscillators in the laboratory is easily carried to frequencies in excess of 1000 Mc by introduction of the oscillator signal at the detector fitting of the calibrator; audible beats are produced as the dial of the oscillator is rotated. The 10-Mc points permit ready identification of calibration points beyond 1000 Mc by a count of the widely spaced beat points on the dial. Below 500 Mc it is possible to add calibration marks at closer intervals by use of the 1-Mc output. The harmonic-generating system is effective in supplying harmonics of 10 Mc to 1500 Mc, and of 1 Mc to 500 Mc, with input signals in excess of 50 mv. The 100-kc and 10-kc multivibrators can be used for oscillator calibration up to 100 Mc and 10 Mc, respectively. Calibration of sensitive receivers is readily carried out by the use of the r-f output harmonic series. With sensitive receivers the harmonics are usable above the frequency limits given for oscillator-calibration operation. When using the calibrator for receiver calibrations, care should be taken that lower harmonics of

the 1- or 10-Mc output signal being used do not block the i-f amplifier. It is possible to block the receiver if a sufficiently strong signal of the harmonic spectrum lies within the i-f pass band. A high-pass filter must be used between the 1213-C and the receiver being calibrated to correct this difficulty.

Measurement of frequencies lying near the standard frequency harmonics is facilitated by the inclusion of the "touch-button" crystal-oscillator frequency deviator on the panel. Touching this button reduces the frequency of the crystal oscillator slightly, thus indicating the sign of the difference between the unknown frequency and the standard frequency, without requiring any resetting of the main frequency adjustment control. Calibration of the sweep time of cathode-ray oscilloscopes is easily carried out: TYPE 1213-P1 Differentiator is inserted in the pair of binding posts connected to the video output amplifier; the selector switch is set to timing markers; and the resulting timing pulses are applied to the scope. Pulses are available at intervals of .1, 1, 10, and 100 μ sec. The accuracy of the intervals is the same as that of the

Figure 7. Waveforms in the Type 1213-C Unit Time/Frequency Calibrator.

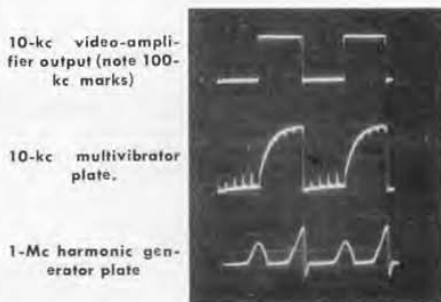



crystal oscillator. Since it is possible to calibrate the crystal oscillator directly against WWV by use of a radio receiver, the accuracy of these timing markers is

much greater than that required for oscilloscopic measurements.

—R. W. FRANK
F. D. LEWIS

The authors are indebted to W. P. Buuck and A. M. Eames for their many suggestions and contributions during the development of the Unit/Time Frequency Calibrator.

SPECIFICATIONS

Output Frequencies: 10 Mc, 1 Mc, 100 kc, 10 kc.
Output Amplitudes: 10 Mc, 10v peak-to-peak, 30 volts peak-to-peak at lower output frequencies from pulse amplifier; r-f harmonics usable to 1000 Mc from 10-Mc output, to 500 Mc from 1-Mc output, to 100 Mc from 100-Kc output, and 10 Mc from 10-kc output.

Output Impedance: Video cathode-follower, 300 ohms; r-f output obtained from crystal-diode harmonic generator.

Stability: After 1 hour warm-up, drift rate with regulated plate supply is mainly the drift rate of the quartz crystal (approx 1 ppm/°C). With unregulated power supply, an additional variation of $\pm 1/2$ ppm with line voltage change from 105 to 125 volts.

Sensitivity: Usable beat notes can be produced

with 50 millivolts signal input to mixer over the harmonic ranges specified under "Output Amplitudes."

Tube Complement: 1-6BE6, 1-5687, 2-5964, 1-6AK6, 1-6ANS, 1-6U8.

Power Supply: 6.3 v a-c, 3 a; 300 v d-c, 60 ma. TYPE 1203-A or TYPE 1201-A is recommended.

Accessories Supplied: TYPE 1213-P1 Differentiator, one coaxial connector, and one multipoint connector.

Mounting: Aluminum panel and sides, finished in black crackle; aluminum cover, finished in clear lacquer. Relay rack panel is available for mounting both calibrator and power supply.

Dimensions: 10 $1/2$ (width) x 5 $3/4$ (height) x 7 (depth) inches, overall. **Net Weight:** 4 lbs, 10 oz.

Type		Code Word	Price
1213-C	Unit Time/Frequency Calibrator *.....	REBEL	\$195.00
1203-A	Unit Power Supply.....	ALIVE	40.00
1201-A	Unit Regulated Power Supply.....	ASSET	80.00
480-P4U3	Relay-rack panel (for mounting both calibrator and power supply).....	UNIPANCART	10.00

* U. S. Patent 2,548,457; licensed under patents of the American Telephone and Telegraph Co.; licensed under patents of the Radio Corporation of America; licensed under patents of G. W. Pierce pertaining to piezo electric crystals and their associated circuits.

VACATION CLOSING

During the weeks of July 23 and July 30, our manufacturing departments will be closed for vacation.

There will be business as usual in the sales-engineering and commercial departments. Orders and inquiries, including requests for technical and sales information, will receive our usual prompt attention.

Our service department requests that, because of absences in the manufacturing and repair groups, shipments of material be scheduled to reach us either well before or delayed until after the vacation period.

GENERAL RADIO COMPANY

275 MASSACHUSETTS AVENUE

CAMBRIDGE 39

MASSACHUSETTS

TELEPHONE: TRowbridge 6-4400

BRANCH ENGINEERING OFFICES

NEW YORK 6, NEW YORK

90 WEST STREET

TEL.—WOrth 4-2722

CHICAGO 5, ILLINOIS

920 SOUTH MICHIGAN AVENUE

TEL.—WAbash 2-3820

LOS ANGELES 38, CALIFORNIA

1000 NORTH SEWARD STREET

TEL.—HOLlywood 9-6201

SILVER SPRING, MARYLAND

8055 13th STREET

TEL.—JUniper 5-1088

PHILADELPHIA OFFICE

1150 YORK ROAD

ABINGTON, PENNSYLVANIA

TEL.—HAncock 4-7419



IET LABS, INC in the GenRad tradition

534 Main Street, Westbury, NY 11590

TEL: (516) 334-9959 • (800) 899-8438 • FAX: (516) 334-9988

www.ietlabs.com

PRINTED
IN
U.S.A.